

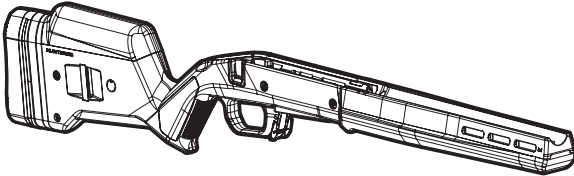

This document contains technology subject to the Export Administration Regulations (15 C.F.R. Parts 730-774). A prior authorization or license from the U.S. Department of Commerce, Bureau of Industry (and Security (BIS)) is required prior to the export, re-export, release, or transfer of this document to a non-U.S. person whether in the United States or abroad.



HUNTER 110 STOCK



MAG1069 HUNTER 110 STOCK - SAVAGE® 110 SHORT ACTION

NOTE: The Magpul Hunter 110 Stock was designed for 3rd generation Savage short action Series 10/110 centerfire rifles, with center-feed magazine compatibility, and action screw spacing of 4.40", which began production in 2006.

TOOLS NEEDED
 - 3/16" hex key
 - In-lbs. torque wrench with 3/16" hex driver bit (recommended)

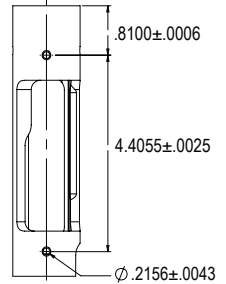

INSTALLATION INSTRUCTIONS

⚠ WARNING: BEFORE STARTING, MAKE SURE THE WEAPON IS UNLOADED, THE CHAMBER IS EMPTY, AND THE SAFETY ENGAGED.

DISASSEMBLE RECEIVER

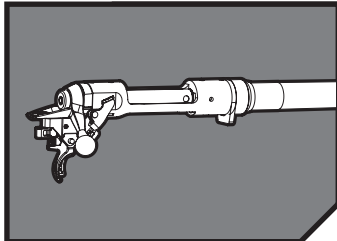

DISASSEMBLE RECEIVER

Remove receiver and action screws from existing stock in accordance with the manufacturer's instructions.

NOTE: The bolt must remain closed and the action un-cocked ("fired") throughout the entire procedure of removing the stock and then reinstalling the action.

INSTALL RECEIVER

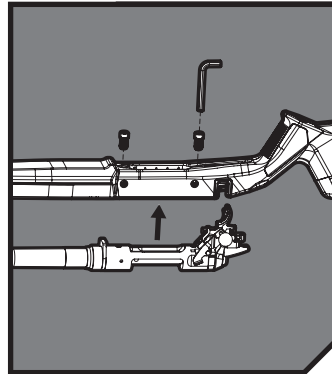

INSTALL RECEIVER

Place the barreled action into the Bedding Block, ensuring the rear surface of the recoil lug is making contact against the rear surface of the Recoil Lug Slot in the Bedding Block.

Insert the two 1/4-28x5/8" Socket Head Cap Screws (Action Screws) and, using a 3/16" hex key, partially engage the threads. Bias the barreled action rearward, ensuring the recoil lug is making contact against the rear surface of the Recoil Lug Slot, and tighten both the front and rear Action Screws.

Using an in-lbs. torque wrench with a 3/16" driver bit, tighten the front and rear Action Screws to 55-60 in-lbs.

CAUTION: Ensure you are using an in-lbs. and NOT a ft-lbs. torque wrench for stock installation. Using the ft-lbs. wrench may lead to stock/action damage.

REMOVE BOLT ACTION MAGAZINE WELL

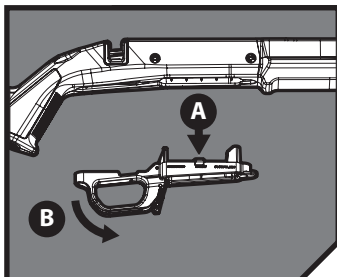

REMOVE BAMW FROM STOCK

To remove the Bolt Action Magazine Well, press inboard midways on both sides of the Magazine Well (A) until the Locking Tabs disengage from the Stock then pull down via the Trigger Guard (B).

INSTALL BOLT ACTION MAGAZINE WELL

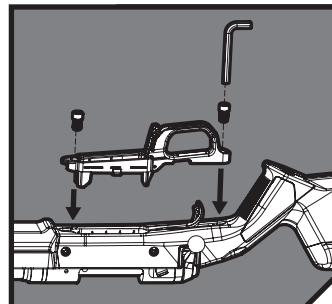

INSTALL BAMW

Insert the Bolt Action Magazine Well until the two Locking Tabs snap into the bottom of the stock. Insert two 1/4-28 x 1/2" Socket Head Cap Screws and hand tighten (approximately 20 in-lbs.).

CAUTION: DO NOT overtighten as this may cause damage to the Bolt Action Magazine Well and/or Bedding Block.

NOTE: Always function check per weapon manufacturer's instructions and test fire your weapon before using it in an operational environment.

LENGTH OF PULL ADJUSTMENT

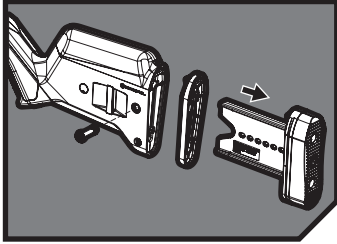

STEP 1: LENGTH OF PULL ADJUSTMENT

Remove the *Butt-Pad Slider* by loosening the *Dual-Drive Slider Screw* and removing. The *Slider* can then be pulled out of the back of the stock.

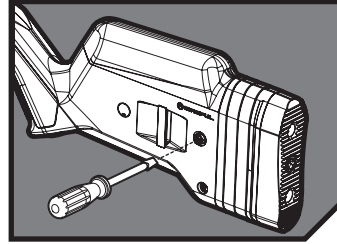

STEP 3: LENGTH OF PULL ADJUSTMENT

Re-install *Butt-Pad Slider* by sliding back into *Stock*, with tab on front of *LOP Spacer* or *Butt-Pad Slider* fitting into slot on rear of *Cheek Riser*. Re-install *Slider Screw* and tighten with *screwdriver*.

Caution: Do not over tighten. Over tightening can cause damage to the *Stock* or *Slider*.

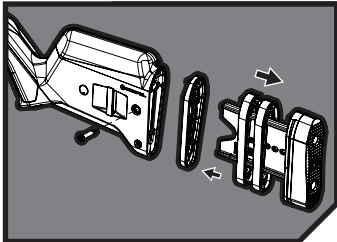

STEP 2: LENGTH OF PULL ADJUSTMENT

Add 1/2" *LOP Spacer* onto the *Butt-Pad Slider*. *Spacers* nest into each other with the open end toward the *Butt-Pad*. Up to 4 *Spacers* can be installed to achieve desired *LOP*. No more than 4 *LOP Spacers* for a total length of 2 extra inches can be used.

Warning: DO NOT use with *Butt-Pad Slider* extended without *LOP Spacers* between *Slider* and *Stock*, as damage to *Stock* can result.

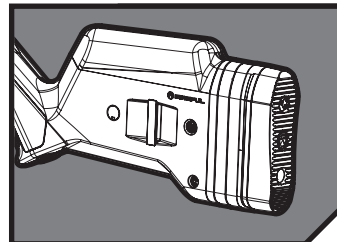

STEP 4: VERIFY INSTALL

Perform final inspection including functions test to verify correct installation. If you experience any issues during installation, please refer to the "Related Info" tab, located on the product page at magpul.com.

Note: Always test fire your weapon before using it in an operational environment.

CHEEK RISER INSTALLATION

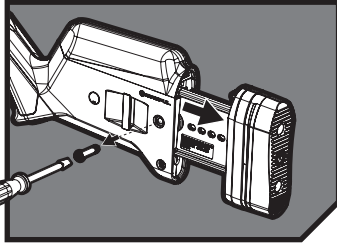

STEP 1: LOP SLIDER REMOVAL

Remove the *Butt-Pad Slider* by loosening the *Dual-Drive Slider Screw* and removing. The *Slider* can then be pulled out of the back of the stock.

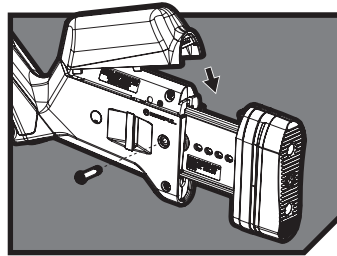

STEP 3: INSTALL CHEEK RISER

Place desired *Cheek Riser* onto *Stock Body* by hooking the front tab into the *Stock Body* first, then lowering the rear into place.

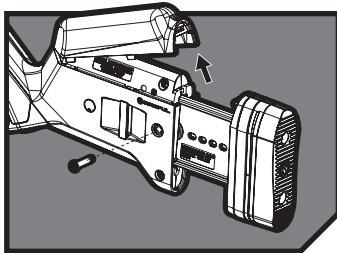

STEP 2: REMOVE ORIGINAL CHEEK RISER

Lift and remove *Cheek Riser* away from *Stock Body*.

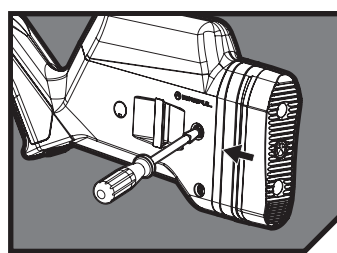

STEP 4: REINSTALL BUTT-PAD SLIDER

Re-install *Butt-Pad Slider* by sliding back into *Stock*, with tab on front of *LOP Spacer* or *Butt-Pad Slider* fitting into slot on rear of *Cheek Riser*. Re-install *Slider Screw* and tighten with *screwdriver*.

Caution: Do not over tighten. Over tightening can cause damage to the *Stock* or *Slider*.

DOMESTUD SLING MOUNTS INSTALLATION

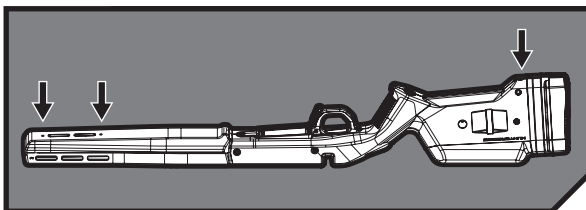

DOMESTUD SLING MOUNTS

Drill points provided for dome stud sling swivels front and rear. Use #10-32 X 3/8" long dome stud swivels.

Drill front and rear dimples using a #21 (0.159") drill, mark drill bit to allow for a max hole depth of .375"-.400" front and rear. For best results cut threads into plastic with a #10-32 tap.

WARNING: Drilling deeper may damage the stock. Please consult a gunsmith for professional installation.